

<b>Ref</b>	<b>Delenummer</b>	<b>Beskrivelse</b>	<b>Ant.</b>
	10-17-000-(See Note 1)	TRANSMISSION ASSEMBLY (MODEL 71C)	
	10-18-000-(See Note 1)	TRANSMISSION ASSEMBLY (MODEL 72C)	
1	4775L	OUTPUT SHAFT NUT	1
2	4547BA	COUPLING (10-17 ONL Y)	1
2A	4547AY	COUPLING (10-18 ONLY)	1
3	71-7	BEARING RETAINER (10-17 ONLY)	1
3A	72-7	BEARING RETAINER (10-18 ONLY)	1
4	179859	HEX HEAD BOLT (7/16-14 X 1-1/4)	6
5	103322	LOCKWASHER (7/16) (10-17 ONL Y)	6
6	71C-110	OIL SEAL	1
7	10-00-130-017	BEARING (1 Pkg)	1
7A	10-00-130-018	BEARING (10-17)	1
7B	B309AGS	BEARING (10-18)	1
8	71-147	BEARING RETAINER GASKET (10-17 ONLY)	1
8A	72-147	BEARING RETAINER GASKET (10-18 ONLY)	1
9	**	ADAPTER	1
9A	**	ADAPTER	1
9B	**	ADAPTER	1
10	**	LOCK BOLT (7/16-14 X 7/8)	6
11	**	LOCKWASHER (7/16) (10-18 ONLY)	6
11A	**	LOCKWASHER (7/16) (10-17 ONLY)	6
12	**	HEX HEAD BOLT (7/16-14 X 1-3/4)	2
13	**	LOCKWASHER (7/16)	2
14	**	ADAPTER GASKET	1
15	**	BEARING	1
16	**	RETAINING RING	1
17	10-17-559-001	DIPSTICK	1
17A	10-13-559-001	DIPSTICK TUBE	1
18	20-01-034-003	DIPSTICK TUBE	1
19	71-79B	SHIFT LEVER	1
20	9418892	HEX NUT (5/16-24)	1
21	108579	LOCKWASHER (5/16)	1
22	103340	FLATWASHER (5/16)	1
23	453632	STEEL BALL (5/16)	1
24	71-42	POPPET SPRING	1
25	10-00-640-004	NEUTRAL SWITCH ASSEMBLY	1
26	NO NUMBER	NEUTRAL SWITCH (NSS)	1
27	10-00-141-046	O-RING	1
28	10-16-039-001	VALVE COVER	1
29	179796	HEX HEAD BOLT (1/4-20 X 1/2)	3
30	103319	LOCKWASHER (1/4)	3
31	10-16-099-001	SWITCH CAM	1
32	71-14	VALVE COVER GASKET	1
33	71-A244A	CONTROL VALVE ASSEMBLY	1
34	4821	SNAP RING	1
35	71-246	SPRING RETAINER	1
36	71-242	VALVE SPRING	1
37	71-243	REGULATOR VALVE	1
38	4804H	O-RING	1

39	71-244A	CONTROL VALVE	1
40	71C-A60	PUMP ASSEMBLY	1
41	10-00-183-021	HEX HEAD BOLT (5/16-18 X 1-3/8)	4
42	10-00-044-014	OIL SEAL	1
43	3-61	PUMP GASKET	1
44	4873	WOODRUFF KEY	1
45	71C-A8	FORWARD AND REVERSE ADAPTER ASSEMBLY	1
46	20-00-183-017	CAPSCREW (3/8-16 X 1-1/4)	4
47	NO NUMBER	FORWARD AND REVERSE ADAPTER (NSS)	1
48	4840D	NEEDLE BEARING	1
49	71-144B	GASKET	1
50	X1516H	PIPE PLUG (1/4)	1
51	71-35	REVERSE CLUTCH PISTON	1
52	4805A	CLUTCH SEALING RING	1
53	4804G	O-RING	1
54	71-71	REVERSE CLUTCH PRESSURE PLATE	1
55	72-176	STEEL CLUTCH PLATE	*0-2
56	72-A66B	FRICTION CLUTCH PLATE	*1-3
57	71-97	PRESSURE PLATE SPRING	11
58	71-87A	DOWEL PIN (.312 DIA X .438 LONG)	3
58A	R6-177	DOWEL PIN (.312 DIA X .621 LONG)	3
58B	4622E	DOWEL PIN (.312 DIA X .875 LONG)	3
58C	10-00-043-031	DOWEL PIN (.312 DIA X 1.000 LONG)	3
59	71-15B	* THRUSTWASHER	1
59A	10-16-193-001	THRUSTWASHER	1
60	4822	SNAP RING	1
61	R6A-7-1/2	SNAP RING (10-17 ONLY)	1
61A	4766B	SNAP RING (10-18 ONLY)	1
62	4734	SNAP RING (10-17 ONLY)	1
62A	4559A	SNAP RING (10-18 ONLY)	1
63	10-00-130-017	BEARING (10-17 ONLY)	1
63A	10-00-130-016	BEARING (10-18 ONLY)	1
64	71-70	FORWARD CLUTCH CYLINDER (10-17 ONLY)	1
64A	72-70	FORWARD CLUTCH CYLINDER (10-18 ONLY)	1
65	10-16-124-001	FORWARD CLUTCH PISTON	1
65A	71-45	CLUTCH PISTON SUPERSEDED BY 1016-124-001	1
66	5M-122	O-RING	1
67	5L -36	PISTON SEALING RING	1
68	5C-33	CLUTCH SPRING BEARING RING	1
69	13575	CLUTCH BELLEVILLE SPRING	1
70	4755	SNAP RING	1
71	5C-175A	CLUTCH PRESSURE PLATE	1
72	10-16-166-001	STEEL CLUTCH PLATE (10-17 ONLY)	4
72A	10-16-166-001	STEEL CLUTCH PLATE (10-18 ONLY)	6
73	5C-A66A	FRICTION CLUTCH PLATE (10-17 ONLY)	5
73A	5C-A66A	FRICTION CLUTCH PLATE (10-18 ONLY)	7
74	5L-67	CLUTCH PRESSURE PLATE	1
75	10-00-139-048	SNAP RING (.033-.037 THICK) (10-17 ONLY) (Yellow)	1
75A	10-00-139-049	SNAP RING (.050-.054 THICK) (10-17 ONLY) (Pink)	1
75B	4768	SNAP RING (.050-.054 THICK) (10-18 ONLY) (Green)	1

75C 4768A	SNAP RING (.074-.078 THICK) (10-18 ONL Y) (Orange)	1
75D 4768B	SNAP RING (.096-.100 THICK) (10-18 ONLY) (White)	1
75E 10-00-139-018	SNAP RING(.062-.066 THICK) (10-18 ONLY) (Purple)	1
76 71-6	RING GEAR (10-17 ONLY)	1
76A 10-16-162-001	RING GEAR (10-18 ONLY)	1
77 71-17	THRUSTWASHER	1
78 4806J	SEALING RING	2
79 4495	SNAP RING	1
80 71-40	FORWARD CLUTCH HUB (10-17 ONLY)	1
80A 10-16-179-001	FORWARD CLUTCH HUB (10-18 ONLY)	1
81 218211	WOODRUFF KEY (10-17 ONLY)	1
81A 124553	WOODRUFF KEY (10-18 ONLY)	1
82 71C-3A16	DRIVE GEAR ASSEMBLY (10-17 ONLY)	1
82A 72C-2A16	DRIVE GEAR ASSEMBLY (10-18 ONLY)	1
83 4806B	SEALING RING	4
84 71-9C	BUSHING	2
85 10-17-659-***	PINION CARRIER ASSEMBLY (10-17 ONLY)	1
85A 10-18-659-***	PINION CARRIER ASSEMBLY (10-18 ONLY)	1
86 71-159	THRUSTWASHER (USE W/BUSHING STYLE CASE)	1
86A 10-17-193-001	THRUSTWASHER (USE W/SEALING RING STYLE CASE)	1
87 10-17-036-002	OIL BAFFLE (USED ON 71 C)	1
87A 10-18-036-001	OIL BAFFLE (USED ON 72C)	1
88 10-00-191-002	PLUG (3/8-18)	2
89 4885B	DRYSEAL BUSHING (3/4-14)	1
90 5L-222	SPRING, EARLY MODELS, NO LONGER USED	1
91 35-143	FLAT WASHER, EARLY MODELS, NO LONGER USED	1
92 10-00-238-002	OIL INLET SCREEN	1
93 71C-84	OIL RETURN TUBE	1
94 71C-A98	OIL STRAINER ASSEMBLY	1
95 A4740G	BREATHER	1
96 444866	PIPE PLUG (3/8-18)	1
97 444687	PIPE PLUG (1/8-27)	1
98 10-17-565-***	CASE (10-17 ONLY)	1
98A 10-18-565-***	CASE (10-18 ONLY)	1

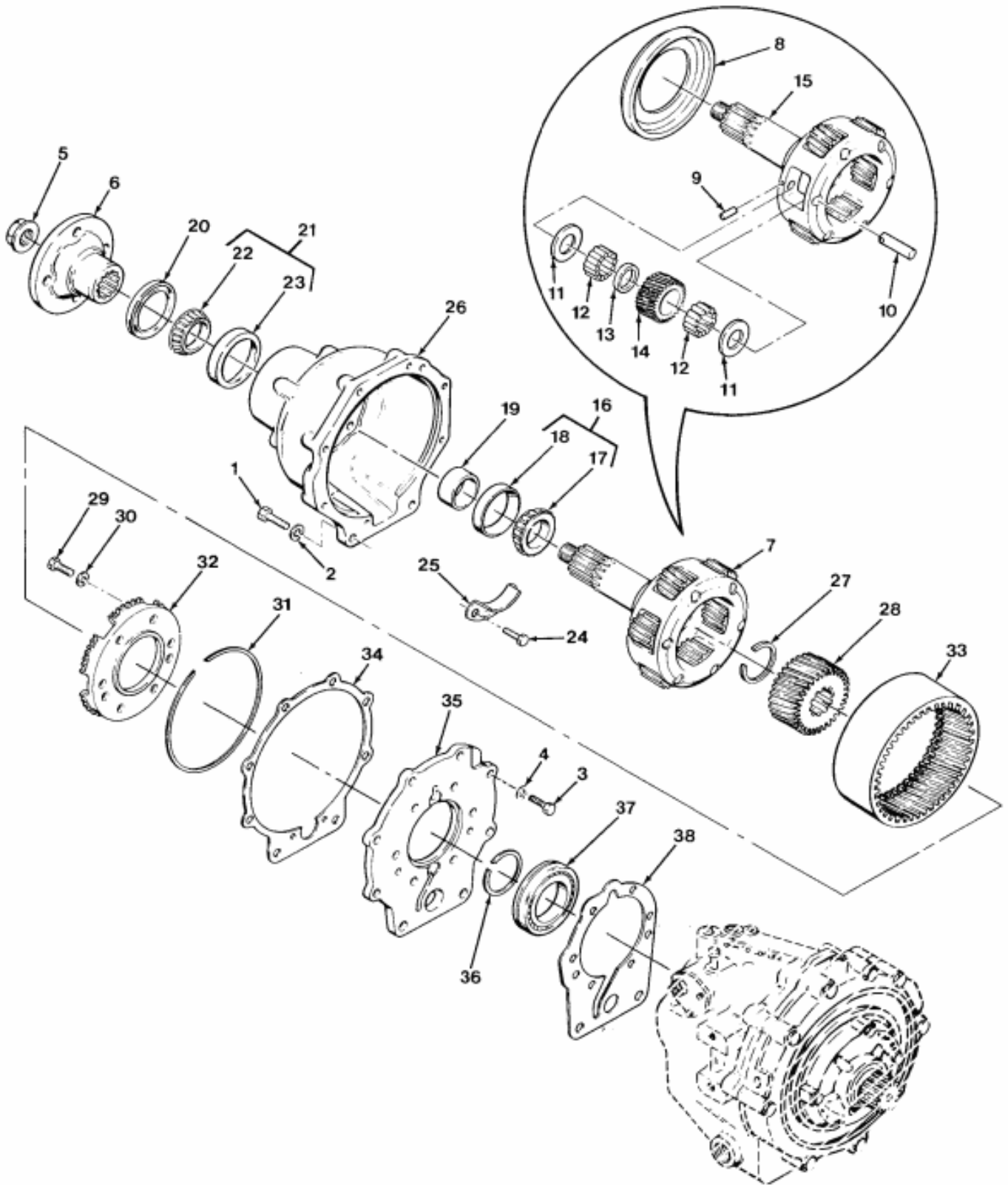

Ref #	Part #	Description	Qty
	None	REDUCTION UNIT ASSEMBLY (2.57:1)	
	None	REDUCTION UNIT ASSEMBLY (2.91:1)	
1	179864	HEX HEAD BOLT (7/16-14 X 1-3/4)	2
2	103322	LOCKWASHER (7/16)	2
3	179840	HEX HEAD BOLT (3/8-18 X 1-1/8)	6
4	103321	LOCKWASHER (3/8)	6
5	10-00-149-034	COUPLING NUT	1
6	10-00-031-001	COUPLING	1
7	10-17-659-007	PINION CAGE AND OUTPUT SHAFT ASSEMBLY (2.57:1 ONLY)	1
7A	10-17-659-008	PINION CAGE AND OUTPUT SHAFT ASSEMBLY (2.91:1 ONLY)	1
8	L6-135	OIL COLLECTOR RING (2.57:1 ONLY)	1
8A	L4-135	OIL COLLECTOR RING (2.91:1 ONLY)	1
9	R10B-40	PINION SHAFT PIN (2.57:1 ONLY)	6
9A	4717L	PINION SHAFT PIN (2.91:1 ONLY)	6
10	L5-39	PINION SHAFT	6
11	L6-43	THRUSTWASHER (2.57:1 ONLY)	12
11A	L3-43	THRUSTWASHER (2.91:1 ONLY)	12
12	4741 A	ROLLER BEARING	288
13	L3-41	PINION BEARING SPACER	6
14	L6-5	PINION GEAR (2.57:1 ONLY)	6
14A	L4-5	PINION GEAR (2.91:1 ONLY)	6
15	10-17-159-003	PINION CAGE AND OUTPUT SHAFT (2.57:1 ONLY)	1
15A	10-17-159-004	PINION CAGE AND OUTPUT SHAFT (2.91:1 ONLY)	1
16	None	BEARING ASSEMBLY	1
17	10-00-133-010	BEARING CONE*	1
18	10-00-133-009	BEARING CUP*	1
19	10-17-053-002	SOLID SPACER (.820-.821 INCH LONG)**	1
19A	10-17-053-003	SOLID SPACER (.829-.830 INCH LONG)**	1
19B	10-17-053-004	SOLID SPACER (.832-.833 INCH LONG)**	1
19C	10-17-053-005	SOLID SPACER (.835-.836 INCH LONG)**	1
19D	10-17-053-006	SOLID SPACER (.838-.839 INCH LONG)**	1
19E	10-17-053-007	SOLID SPACER (.841-.842 INCH LONG)**	1
19F	10-17-053-008	SOLID SPACER (.844-.845 INCH LONG)**	1
19G	10-17-053-009	SOLID SPACER (.847-.848 INCH LONG)**	1
19H	10-17-053-010	SOLID SPACER (.850-.851 INCH LONG)**	1
19I	10-17-053-011	SOLID SPACER (.853-.854 INCH LONG)**	1
19J	10-17-053-012	SOLID SPACER (.856-.857 INCH LONG)**	1
20	10-00-044-017	OIL SEAL	1
21	None	BEARING ASSEMBLY	1
22	10-00-133-002	BEARING CONE*	1
23	10-00-133-001	BEARING CUP*	1
24	4776BB	LOCK BOLT (7/16-14 X 7/8)	2
25	10-17-036-001	OIL BAFFLE	1
26	10-17-065-001	REDUCTION HOUSING	1

27	4734	SNAP RING	1
28	L6-104	SUN GEAR (2.57:1 ONLY)	1
28A	L7-104	SUN GEAR (2.91:1 ONLY)	1
29	4853E	LOCK BOLT (7/16-14 X 1-1/4)	6
30	115550	LOCKWASHER (7/16)	6
31	4756E	SNAP RING (2.57:1 ONLY)	1
31A	4756D	SNAP RING (2.91:1 ONLY)	1
32	L6-31	STATIONARY GEAR PLATE (2.57:1 ONLY)	1
32A	L7-31	STATIONARY GEAR PLATE (2.91:1 ONLY)	1
33	L6-6	RING GEAR (2.57:1 ONLY)	1
33A	L3-6	RING GEAR (2.91:1 ONLY)	1
34	L4-146	REAR ADAPTER GASKET	1
35	L7-8A	REDUCTION UNIT ADAPTER	1
36	4816	SNAP RING	1
37	10-00-130-018	BEARING	1
38	L4-145	FRONT ADAPTER GASKET	1

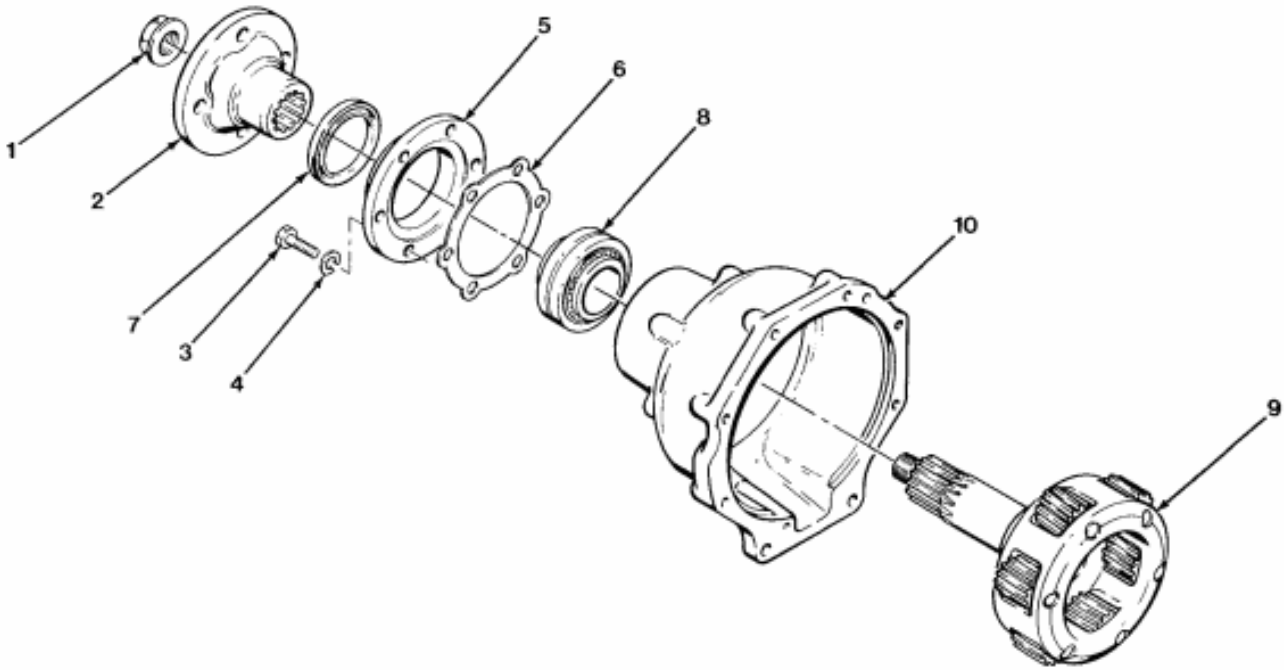

Ref #	Part #	Description	Qty
	None	REDUCTION UNIT (2.57:1 ONLY)	
	None	REDUCTION UNIT (2.91:1 ONLY)	
1	10-00-149-034	COUPLING NUT	1
2	4912	COUPLING	1
3	179860	HEX HEAD BOLT (7/16-14 X 1-1/4)	6
4	103322	LOCKWASHER (7/16)	6
5	L4-7	BEARING RETAINER, NO LONGER SUPPLIED	1
6	L4-147	BEARING RETAINER GASKET	1
7	71C-110	OIL SEAL	1
8	4920	BEARING	1
9	L6-A2D	PINION CAGE AND OUTPUT SHAFT	1
		ASSEMBLY (2.57:1 ONLY), NO LONGER SUPPLIED	
9A	L7-A2D	PINION CAGE AND OUTPUT SHAFT	1
		ASSEMBLY (2.91:1 ONLY), NO LONGER SUPPLIED	
10	L7-1A	REDUCTION HOUSING, NO LONGER SUPPLIED	1